

# VICTORIAN DESALINATION PROJECT

## FACT SHEET

WATER NOW  
AND FOR THE FUTURE.  
FOR SURE.

### MARINE STRUCTURES & UNDERGROUND TUNNELS

Marine structures and tunnels have been carefully designed and located to minimise impacts on the marine environment and to ensure optimal performance of the desalination plant.

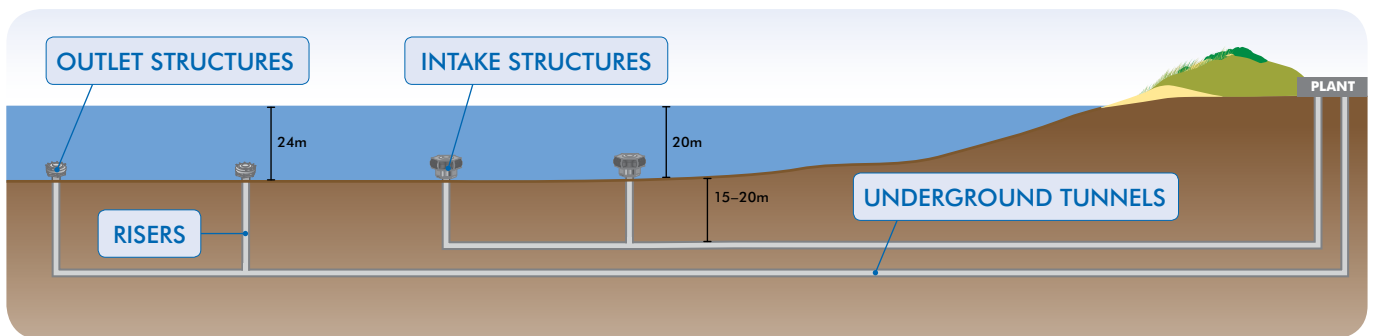

#### About the seawater intake structures

Two seawater intake structures will be constructed on the seabed to draw seawater slowly into the desalination plant.

Vertical risers will connect the intake structures to a 1.2 kilometre underground tunnel.

The intake structures will be capable of supporting the plant operating at 200GL capacity and have been designed to guard against impacts on the marine environment.

The intake structures are made from concrete and each will weigh approximately 200 tonnes.

#### About the outlet structures

Two outlet structures will be constructed on the seabed to return seawater concentrate to the ocean at the end of the desalination process.

Vertical risers will connect the outlet structures to a 1.5 kilometre underground tunnel.

The outlet structures will be fitted with nine diffuser nozzles each, designed to ensure rapid dilution of the seawater concentrate.

The diffuser nozzles are designed to support the plant operating at 150GL. In the event that the plant is upgraded to 200GL, it will be a simple exercise to fit larger nozzles.

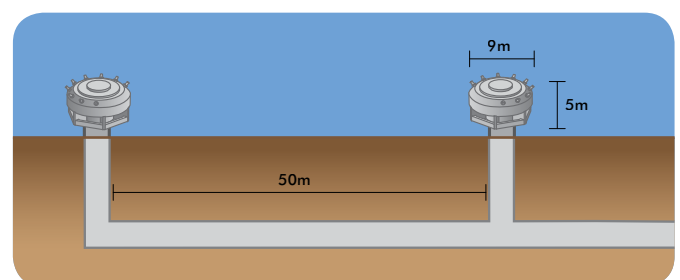
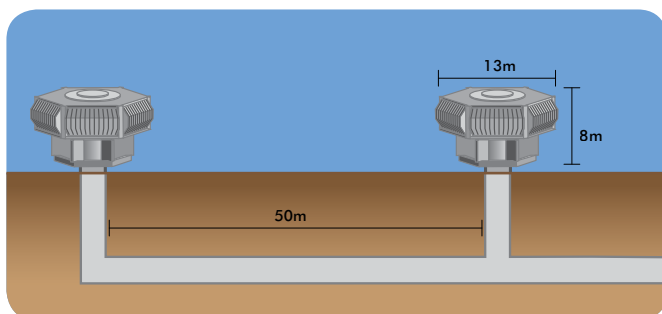

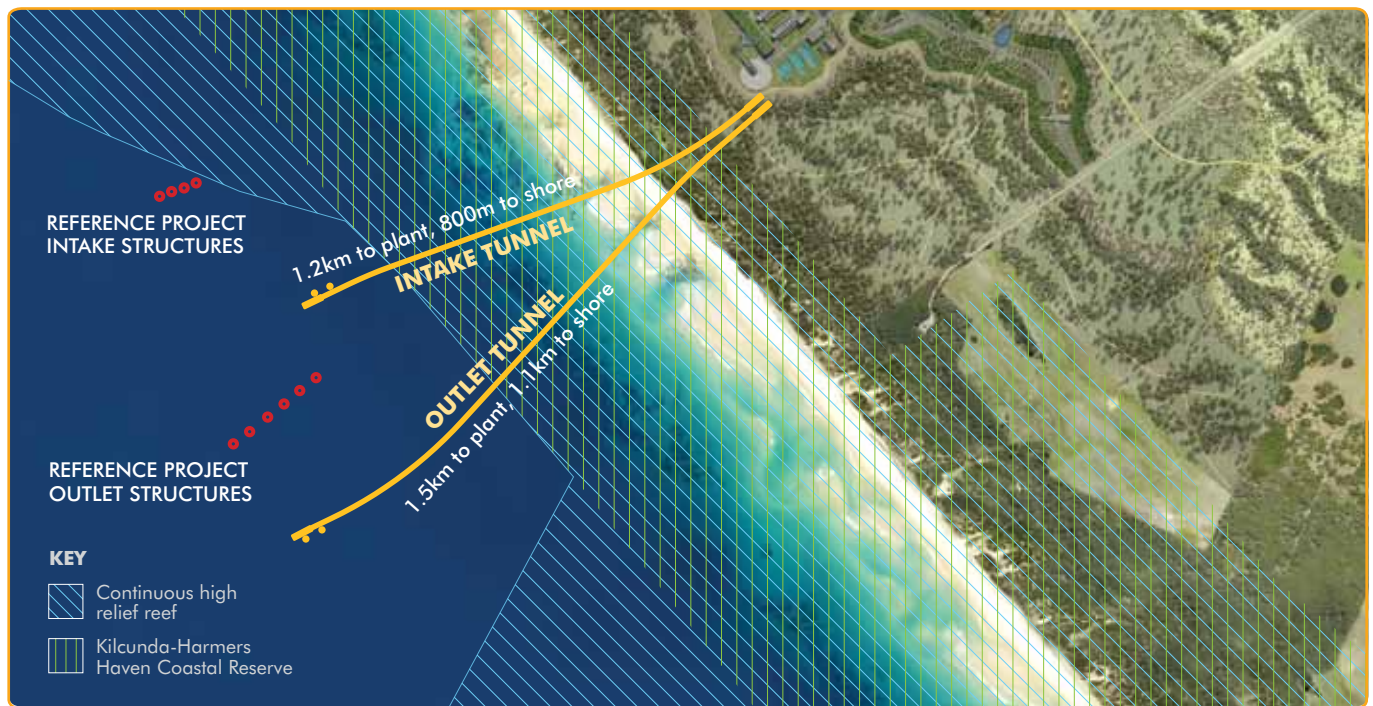

### Where will the marine structures be located?

The intake structures will be located approximately 1.2 kilometres from the plant site, or around 800 metres from the Williamsons Beach shoreline.

The outlet structures will be located approximately 1.5 kilometres from the plant site, or around 1.1 kilometres from the shoreline.

The intake and outlet structures will be more than 500 metres apart and all structures will be located well beyond marine sensitive areas.

### Is AquaSure's design different from the reference project?

Yes. In the early stages of the project, a 'reference project' and variations were developed so that the potential environmental and social impacts of the project could be assessed during the Environment Effects Statement (EES) process.

The benefit of this was to enable the assessment of potential impacts and to define performance requirements, while still allowing scope for further innovation from the bidders which might enhance the design and therefore, the performance of the project.

The performance requirements adopted from the EES process were developed to ensure the environment was protected by any design.

The reference project proposed **four** intake structures and **four** outlet structures for a 150GL plant, increased to six outlet structures for a 200GL plant.

AquaSure's design requires only **two** intake structures and **two** outlet structures, **regardless** of whether the plant is upgraded.

### What are the benefits of AquaSure's design?

AquaSure's design will deliver a range of improved environmental outcomes for the project:

- First outlet located further offshore and further away from marine sensitive areas identified in the EES
- Outlet structures in deeper water, allowing more rapid mixing of seawater concentrate
- Intake structures located further away from high relief reef areas
- Smaller construction footprint
- Smaller area of increased salinity around the outlet structures, proven by hydrodynamic modelling
- No additional construction required – if plant is upgraded, it will be a simple exercise to fit larger nozzles

### How were the marine structures locations decided?

Finalising the locations involved significant investigation work, detailed design and modelling, starting with the EES completed for the project in 2008.

AquaSure has continued this research since being awarded the contract in July 2009 and an extensive biological assessment has been undertaken to better understand the marine environment.

### Wouldn't it be better to locate the structures further out to sea?

No. Studies and modelling undertaken confirm that locating the marine structures further out to sea would have no significant environmental benefit.

### Wouldn't it be better to have six outlets rather than two?

Computer modelling predicts that the area of increased salinity for the two outlet solution is likely to be smaller compared to the six outlet solution.

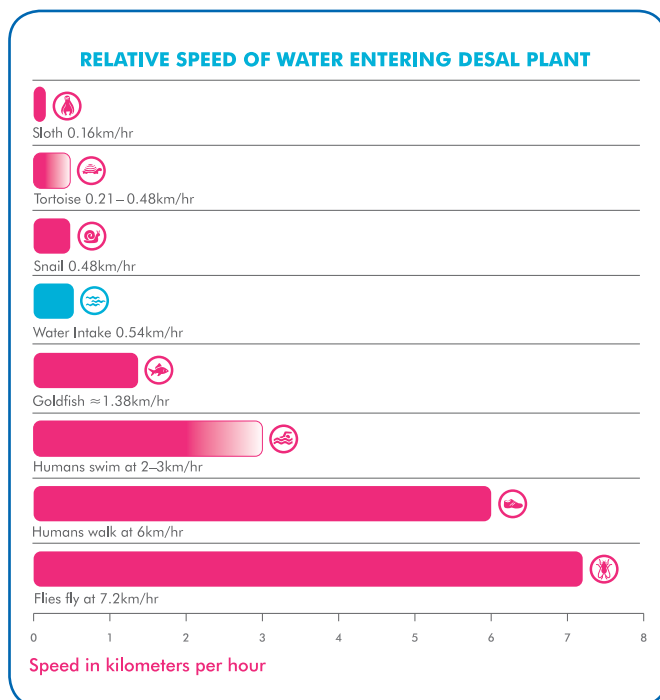

Seawater will be drawn into the plant at very low speed.

### Will the intake structures draw in marine life?

Seawater will be drawn in at very low speeds – even small fish will be able to swim against the intake current – and a protective grille will ensure that larger marine life can't swim into the structure.

Marine larvae and plankton may be drawn into the plant, however biological studies confirmed that the entrainment would be a very small proportion and highly unlikely to impact on population sizes or ecosystems processes.

### How will the seawater concentrate be diluted?

The outlet structures have been designed to mix seawater concentrate with standard seawater quickly and efficiently.

Seawater concentrate will be discharged through specially designed diffuser nozzles at a rate of approximately six metres per second.

### Who approved the design of the intake and outlet structures?

The design has passed through a comprehensive approvals process, including review by the Independent Reviewer & Environmental Auditor for the Project and final assessment by the EPA to assess its compliance with the EPA Works Approval.

Due to the open ocean currents of Bass Strait and the efficiency of the outlet design, the salt content of the mixed water is predicted to drop back to standard seawater concentrations within a short distance of the outlet structures.

### Will the seawater concentrate harm marine life?

Research predicts that the point at which 99% of marine life in the local ecosystem will be protected lies within a short distance of the outlet structures.

### Has the performance of the outlet structure design been tested?

Yes. Computerised hydrodynamic modelling was carried out for different locations and confirmed that the design will deliver optimal performance.

The accuracy of these results was tested and verified in a physical model, built in a laboratory.

### How will the marine structures and underground tunnels be built?

The marine structures and underground tunnels involve two separate construction activities.

Construction of the underground tunnels is a land-based activity carried out approximately 15 metres under the seabed, involving a tunnel boring machine.

Construction of the marine structures is sea-based, involving the use of a jack-up barge.

### Further reading

- Understanding the Marine Environment Fact Sheet
- Jack-Up Barge Fact Sheet
- Tunnel Boring Machine Fact Sheet

**WATER NOW  
AND FOR THE FUTURE.  
FOR SURE.**

## **CONTACT US**

**Visit the Victorian Desalination Project Community Information Centre  
Shop 2, 33–35 Murray St, Wonthaggi**

### **Opening hours**

Tuesday–Friday 9.30am–4.30pm, Saturday 9am–12pm.



**FREECALL**  
1800 811 214



**EMAIL**  
contactus@aquasure.com.au



**WEB**  
www.aquasure.com.au



**POST**  
**AquaSure C/– PO Box 7387**  
St Kilda Road, Melbourne  
VIC 8004

SEPTEMBER 2010

